

MELUCK

Enjoy the future with science

Copeland Hermetic Scroll Compressor Condensing Unit(60hz)



美乐柯集团
MELUCK Group

MELUCK Group Company Profile

Meluck Group is a comprehensive company integrating design, research and development, production, sales and service. It specializes in the production of integrated commercial freezing and refrigeration equipment and operates the "Meluck" brand. Our company has got licence of imports&exports rights, belongs to the group member of China Refrigeration Society, the group member of China Quality Inspection Society, the member of China Intellectual Property Protection Association, obtained the special equipment manufacturing license of the People's Republic of China and the national industrial product production license. It is a national high-tech enterprise with C2 qualification of "Refrigeration and Air Conditioning Maintenance and Installation" and pressure pipe design and installation GC2. It is the first ones in the industry to pass "Enterprise Standards" and ISO9001, ISO14001, ISO18001 management system certification, and passed 《National safety production standardization》

Since its establishment in 1992, Meluck Group has become a leading enterprise in commercial refrigeration integrated equipment through the continuous efforts of all employees of the company. So far, the company has 200 acres of production base, more than 300 employees, products and service solutions have been applied to more than 70 countries around the world, providing solutions for tens of millions of cold chain needs.

The company has strong refrigeration technology reserves, advanced production lines and testing equipment. According to product manufacturing requirements, a complete production system process and a complete quality assurance system have been established. At the same time, the company has a series of complete promotion channels, training systems, and salary systems, which guarantee the construction of corporate talent echelon and personal growth of employees. The company focuses on investment in scientific and technological innovation. At present, many key components developed by itself have applied for national patents. By 2019, it has 5 invention patents and 36 utility model patents.

The company main products are: industrial chiller, screw condensing unit, rotor condensing unit, scroll condensing unit, piston condensing unit, ceiling mounted Evaporator, double-side blowing Evaporator, showcase Evaporator, standing Evaporator, air-cooled Condenser, shell and tube condenser, shell and tube evaporator, pressure vessel and many other related products.

Corporate vision: Committed to making Meluck a century-old enterprise.

Enterprise mission: To be the best service provider of integrated freezing and refrigeration systems in the industry.

Corporate culture: customer-centric, quality-oriented, simple and efficient, co-creating, sharing

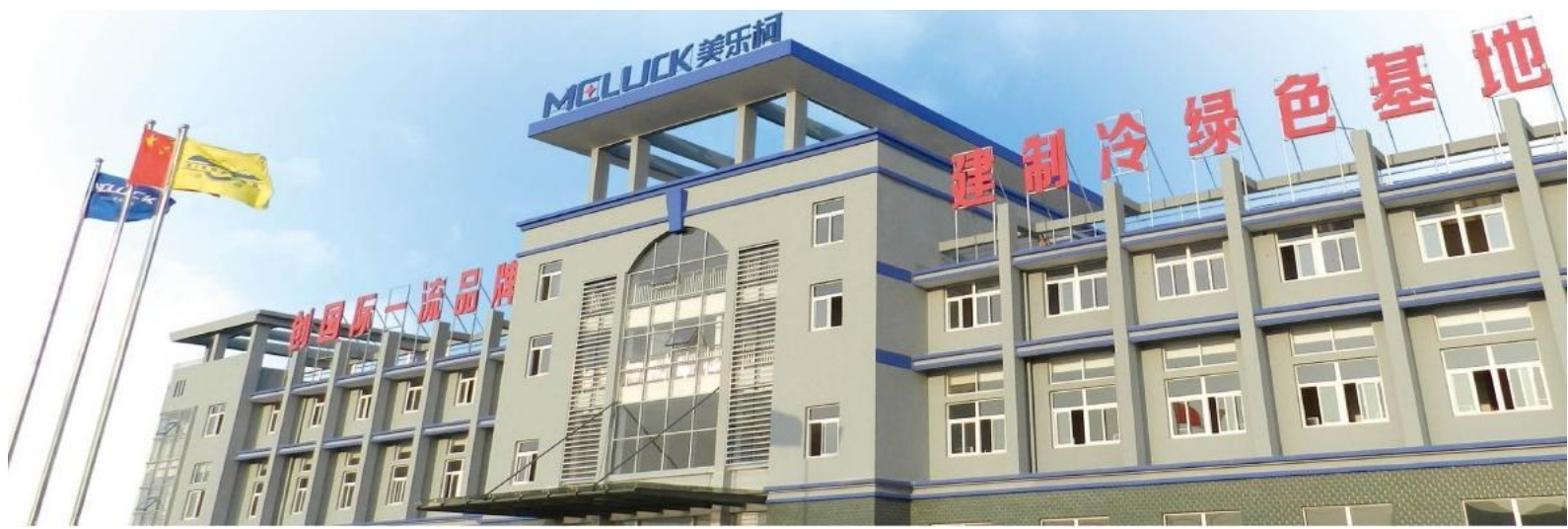

美乐柯集团

MELUCK GROUP

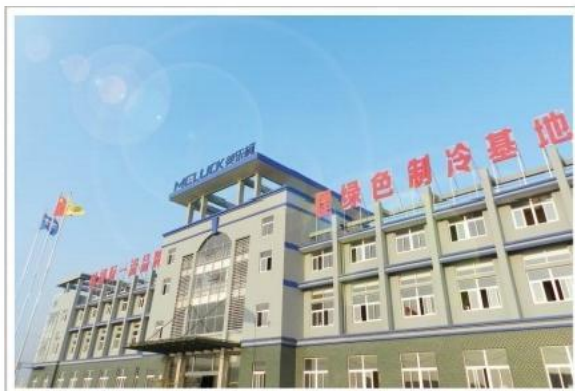

安徽工厂——总部 Anhui Meluck Factory——Headquarter

美乐柯安徽工厂—安徽美乐柯空调设备有限公司总投资1.65亿元，占地200亩，是目前国内最大的制冷设备生产制造基地之一，专业制造和研发风冷凝器、蒸发器、冷凝机组、工业冷水机等制冷设备，公司2012年底已正式投入生产。

Anhui Meluck Refrigeration Air-condition Equipment Co.,Ltd.invested about U.S dollar Twenty Six Million,with 130000m²area;is one of the biggest refrigeration equipment manufacturing bases in China,specialized in manufacturing and researching for the refrigeration equipments like air cooled condenser,evaporator,condensing unit,industry chiller etc.the factory has started production in 2012.



上海美乐柯 Shanghai Meluck

上海美乐柯营销与服务中心，公司内有40名专业的销售和技术服务人员，为全球客户提供专业的技术支持和服务，公司具有GC2设计资质与安装资质，机电安装资质等众多权威资质，能为客户提供整体方案设计与选型服务。

Shanghai Meluck Marketing and Service Center consist of 40 skilled sales and technicians,providing professional technical supports and services to global customers.The company has GC2 design qualification and installation qualification,electromechanical installation qualification and many other authoritative qualifications.Can provide customers with overall program design and model selection services.



企业资质 Enterprise Qualification

不断创新，确保客户对我们的产品满意，被我们的服务感动，争创名优！
Innovation, for the customer's satisfaction, With our excellent service and product

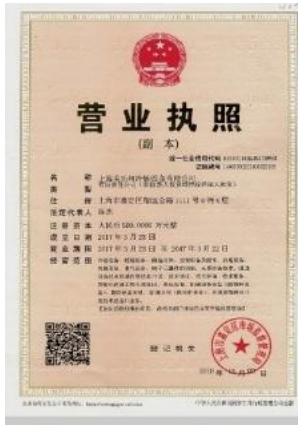

上海营业执照
Shanghai Business License



安徽营业执照
Anhui Business License

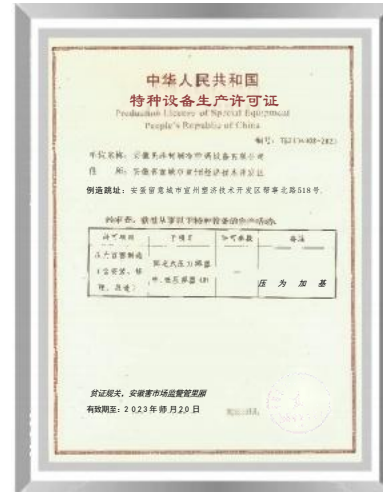

特种设备制造许可证
Certificate for Special High Pressure Vessel Manufacturing

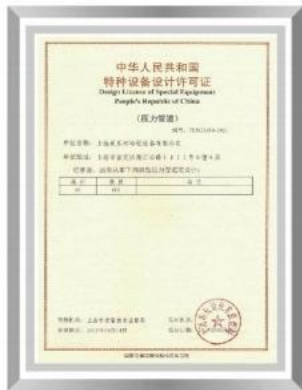

压力管道设计证书
Pressure piping design certificate

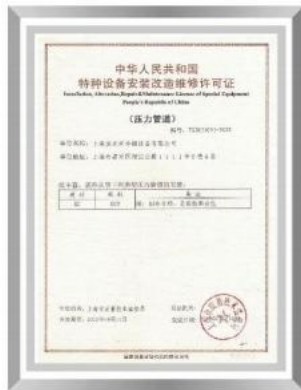

压力管道安装证书
Pressure piping installation certificate



环境管理体系认证证书
Environmental management system certification



质量管理体系认证证书
Quality management system certification



安徽省商标品牌示范企业
Anhui Province Trademark Brand Demonstration Enterprise



高新技术企业证书
High-tech Enterprise Certificate



省认定企业技术中心证书
Provincial Certification of Enterprise Technology Center

一流的生产线

Advanced Machines Guarantee High Quality

精益化的生产节拍，标准化的工艺流程，通过优质的产品体现“美乐柯”的品牌价值

Advance equipment created excellent production, and high quality of Meluck products.



全夏范

英乐何集团

· 质量是品牌的生命 · 责任是质量的保证

MELUEK



先进的生产设备

Advanced Machines Guarantee High Quality

先进的设备和精湛的生产工艺，铸就了美乐柯产品的优秀品质！

Advance equipment created excellent production, and high quality of Meluck products.



静电粉末喷涂生产线
Static electricity powder painting production line



数控折弯机
CNC bending machine



数控激光切割机
CNC laser cutting machine



卧式胀管机
Horizontal Type Pipe Expansion Machine



四柱油压机
4Column Oil Pressing Machine



高速翅片冲压线
High-speed fin press line



数控5轴相贯线切割机器人
CNC5-axis intersecting wire cutting robot

XJQ Series Scroll Hermetic Comp Condensing Unit(60HZ)

1、 Features:

According to the development needs of foreign markets,our company has launched the XJQ series hermetic box-type condensing unit upgraded products (applied at 60HZ),which can be used in chiller room-5℃~5℃ and freezer room-18℃~-20℃ respectively,and are widely used.In hotels,restaurants,food,health,medicine,agriculture and other industries.

This series of products has the following characteristics:

- ◆ Condensing unit main control board,cold room temp control board and operation board.Cold room temp control board and operation board are optional.
- ◆ "-K"model the compressor starts and stops according to the system low pressure,and can be used in supermarkets,milk tanks,chillers,etc.;"-E"model compressor is controlled by room temperature.With room temp and defrosting function and can be directly used in cold rooms without the need for additional electrical appliances and controllers;
- ◆ The electronic control has various protections such as phase sequence,phase loss,over-current,frequent compressor starts, exhaust temperature,system high and low pressure,etc.
- ◆ If the unit is equipped with electric control,it has the unit operating parameter query function,and you can check the compressor operating current,exhaust temperature,condensing temperature and other operating parameters.
- ◆ If the unit is powered by electricity,it has unit operation fault alarm and query functions.When the unit fails,the buzzer will sound an alarm to remind the user in time;
- ◆ The operation panel for room temperature control has functions such as temperature display,setting,defrost control, operating parameter query,storage temperature alarm,etc.I is installed separately from the unit and can be installed in a place convenient for users to operate and monitor.

II、 Model Description:

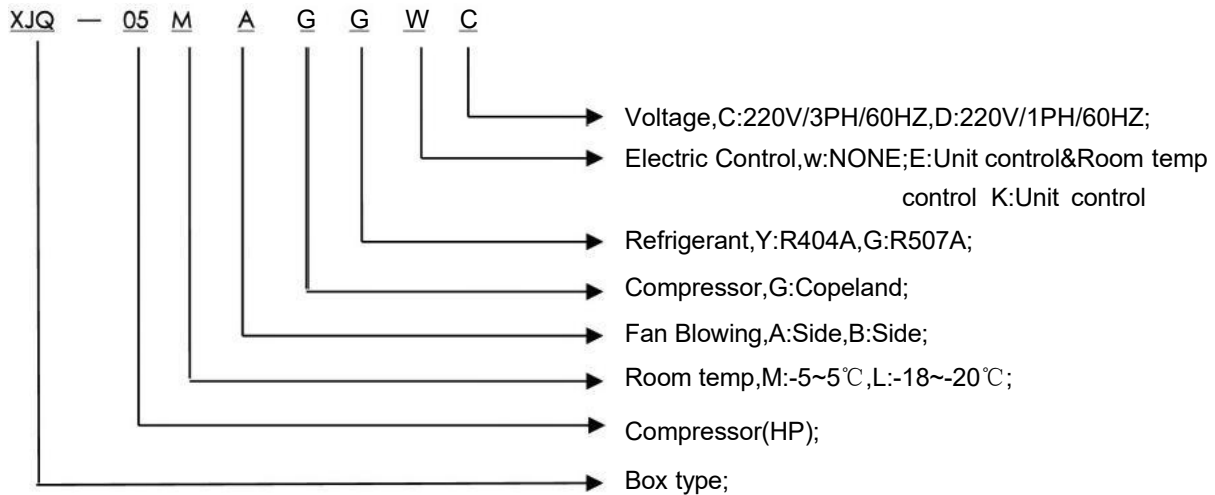

III、 Unit configuration instructions:

- ①Compressor ②Exhaust temperature protector ③Oil heating belt ④Condenser ⑤liquid receiver
⑥Filter drier ⑦Sight glass ⑧Electromagnetic valve ⑨Diaphragm pressure switch ⑩High and low pressure gauge
⑪Inlet and outlet pipe interface valve ⑫Mechanical low pressure control ⑬Oil separator ⑭Gas-liquid separator
⑮Mechanical high and low pressure control ⑯Electric control

XJQ03M:Standard ①、 ②、 ③、 ④、 ⑤、 ⑥、 ⑦、 ⑧、 ⑨、 ⑩、 ⑪、 ⑬;Optional:⑫、 ⑮、 ⑯

XJQ04M-XJQ6M:Standard ①、 ②、 ③、 ④、 ⑤、 ⑥、 ⑦、 ⑧、 ⑨、 ⑩、 ⑪、 ⑬;Optional:⑫、 ⑭、 ⑮、 ⑯

XJQ02L-XJQ04LStandard ①、 ②、 ③、 ④、 ⑤、 ⑥、 ⑦、 ⑧、 ⑨、 ⑩、 ⑪、 ⑫、 ⑬;Optional:⑮、 ⑯

XJQ05L-XJQ06L:Standard ①、 ②、 ③、 ④、 ⑤、 ⑥、 ⑦、 ⑧、 ⑨、 ⑩、 ⑪、 ⑫、 ⑬、 ;Optional:⑮、 ⑯

Note:For units with only main control,the mechanical low-pressure pressure control No.12 is standard.

The main technical parameters:

Medium temperature series:Refrigerant R507A

Model		XJQ02MAGGWD	XJQ03MAGGWD	XJQ02MAGGWC	
Room Temp(°C)		-5°C~5°C			
Power supply		220V/1PH/60HZ		220V/3PH/60HZ	
Compressor Model		ZB15KNE-PFV-558	ZB21KNE-PFV-558	ZB15KNE-TF5-558	
Condenser	Fan QTY	1	1	1	
	Fan Voltage(V)	220	220	220	
	Fan Power(W)	90	90	90	
Comp capacity&Input	Evap Temp -5°C	Capacity(W)	5320	7770	5020
		Power(W)	2090	3080	1985
	Evap Temp -7°C	Capacity(W)	4950	7220	4670
		Power(W)	2080	3060	1970
	Evap Temp -10°C	Capacity(W)	4420	6460	4180
		Power(W)	2060	3020	1935
Connections	Suction Line (mm)	φ 19	φ 19	φ 19	
	Liquid Line (mm)	φ 10	φ 10	φ 10	
Dimensions	L (mm)	965	965	965	
	W (mm)	410	410	410	
	H (mm)	850	850	850	
Installation sizes(A×B) (mm)		581×380	581×380	581×380	
Shell Model		A Model			

Note:1)Condensing Temp 45°C;

Medium temperature series:Refrigerant R507A

Model		XJQ03MAGGWC	XJQ04MAGGWC	XJQ05MAGGWC	
Room Temp(°C)		-5°C~5°C			
Power supply		220V/3PH/60HZ			
Compressor Model		ZB21KNE-TF5-558	ZB29KNE-TF5-558	ZB38KNE-TF5-558	
Condenser	Fan QTY	1	2	2	
	Fan Voltage(V)	220	220	220	
	Fan Power(W)	90	90×2	90×2	
Comp capacity&Input	Evap Temp -5°C	Capacity(W)	7530	9810	12350
		Power(W)	3060	3900	4920
	Evap Temp -7°C	Capacity(W)	7000	9130	11500
		Power(W)	3030	3900	4920
	Evap Temp -10°C	Capacity(W)	6260	8180	10300
		Power(W)	2980	3890	4920
Connections	Suction Line (mm)	φ 19	φ 19	φ 19	
	Liquid Line (mm)	φ 10	φ 12	φ 12	
Dimensions	L (mm)	965	965	965	
	W (mm)	410	410	410	
	H (mm)	850	1250	1250	
Installation sizes(A×B) (mm)		581×380	581×380	581×380	
Shell Model		A Model	B Model		

Note:1)Condensing Temperature 45°C;

Dimensions and Installation Diagram

A Model

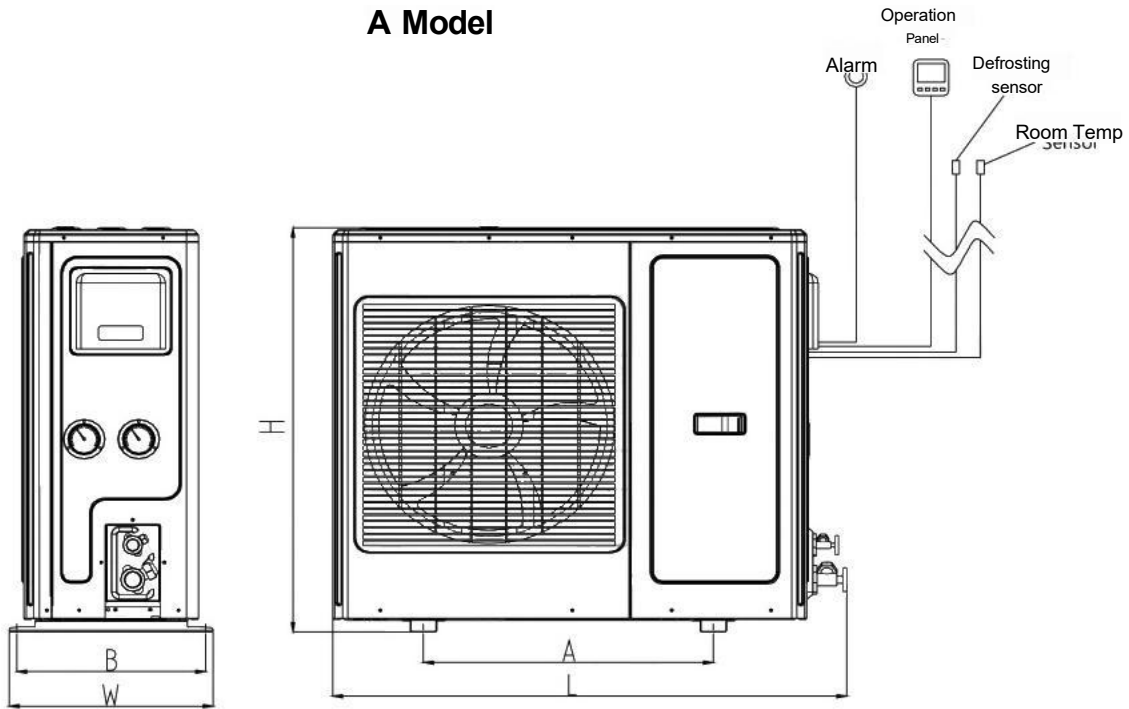

B Model

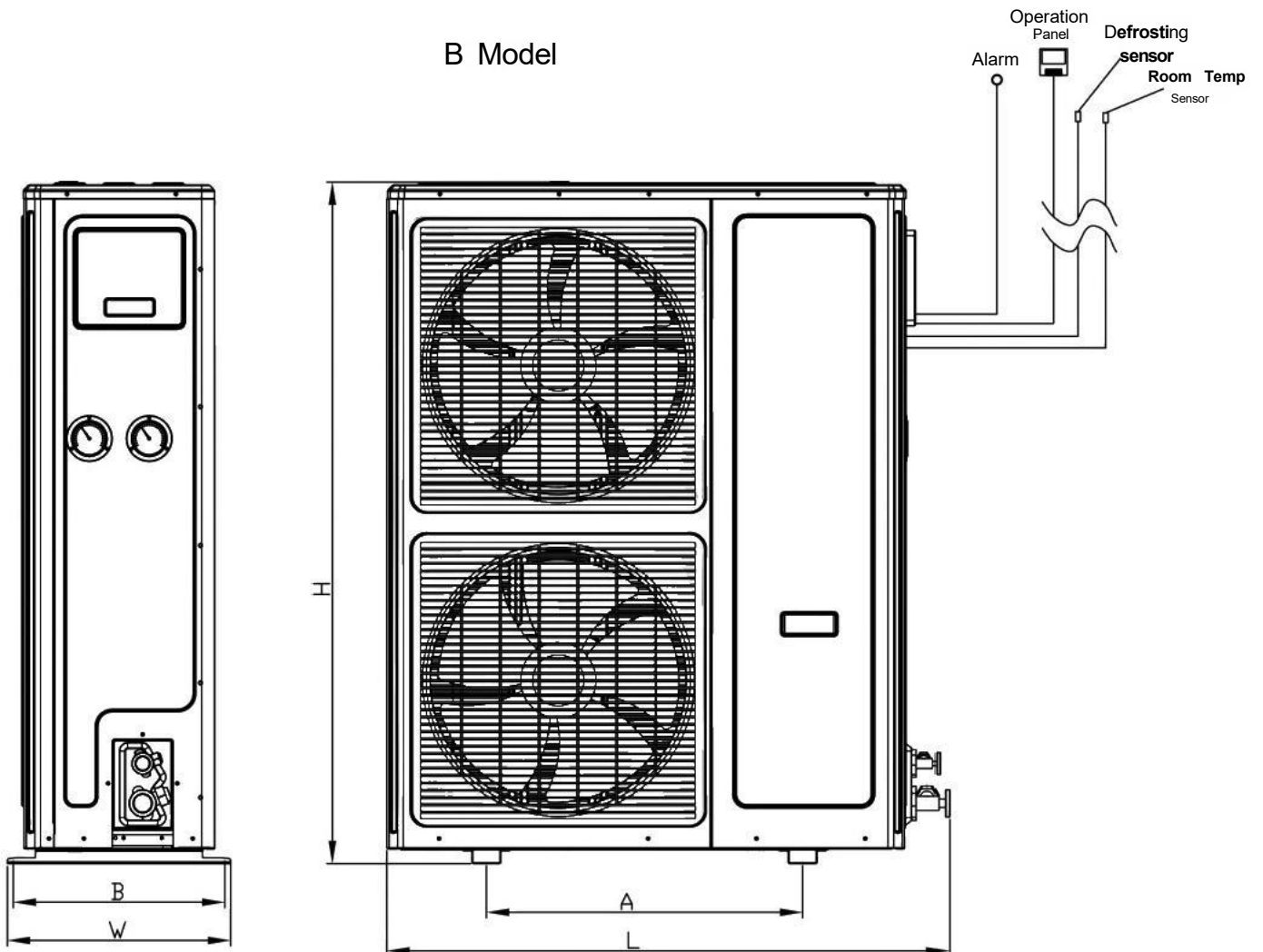

www.chinameluck.com

MELUCK

Enjoy the future with science



安徽美乐柯制冷空调设备有限公司

Anhui Meluck Refrigeration Air-condition Equipment Co.,Ltd.

地址：安徽省宣城市宣州经济开发区昭亭北路518号

Add:No 518,North Zhaoting Road,High-tech Zone,Xuancheng city,Anhui Province.

电话/Tel:+86-563-2527768 传真/Fax:+86-563-2527758

邮箱/E-mail:meluck1@sh-meluck.com



上海美乐柯冷链设备有限公司

Shanghai Meluck Refrigeration Equipment Co.,Ltd.

地址：上海市嘉定区惠平路801号1幢11层1106室、1107室

Add:Room 1106&1107,1#building,No 801,Huiping Road, Jiading District,shanghai.

电话/Tel:+86-21-39199148 传真/Fax:+86-21-39199150

邮箱/E-mail:meluck1@sh-meluck.com



facebook

我司对样本中的各类技术参数保留自行更改而不另行通知的权利。
Our company reserves the right to modify the specification int

2024年7月